

Class 2 Bluetooth® Module

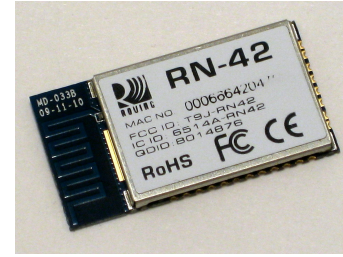

Features

- Fully qualified Bluetooth 2.1/2.0/1.2/1.1 module
- Bluetooth v2.0+EDR support
- Available with on board chip antenna (RN-42) and without antenna (RN-42-N)
- Postage stamp sized form factor, 13.4mm x 25.8 mm x 2mm (RN-42) and 13.4mm x 20 mm x 2 mm (RN-42-N)
- Low power (*26uA sleep, 3mA connected, 30mA transmit*)
- UART (SPP or HCI) and USB (HCI only) data connection interfaces.
- Sustained SPP data rates - 240Kbps (slave), 300Kbps (master)
- HCI data rates - 1.5Mbps sustained, 3.0Mbps burst in HCI mode
- Embedded Bluetooth stack profiles included (*requires no host stack*): GAP, SDP, RFCOMM and L2CAP protocols, with SPP and DUN profile support.
- Bluetooth SIG certified
- Castellated SMT pads for easy and reliable PCB mounting
- Certifications: FCC, ICS, CE
- Environmentally friendly, RoHS compliant

Applications

- Cable replacement
- Barcode scanners
- Measurement and monitoring systems
- Industrial sensors and controls
- Medical devices
- Barcode readers
- Computer accessories

Description

The RN42 is a small form factor, low power, highly economic Bluetooth radio for OEM's adding wireless capability to their products. The RN42 supports multiple interface protocols, is simple to design in and fully certified, making it a complete embedded Bluetooth solution. The RN 42 is functionally compatible with RN 41. With its high performance on chip antenna and support for Bluetooth® Enhanced Data Rate (EDR), the RN42 delivers up to 3 Mbps data rate for distances to 20M. The RN-42 also comes in a package with no antenna (RN-42-N). Useful when the application requires an external antenna, the RN-42-N is shorter in length and has RF pads to route the antenna signal.

Block Diagram

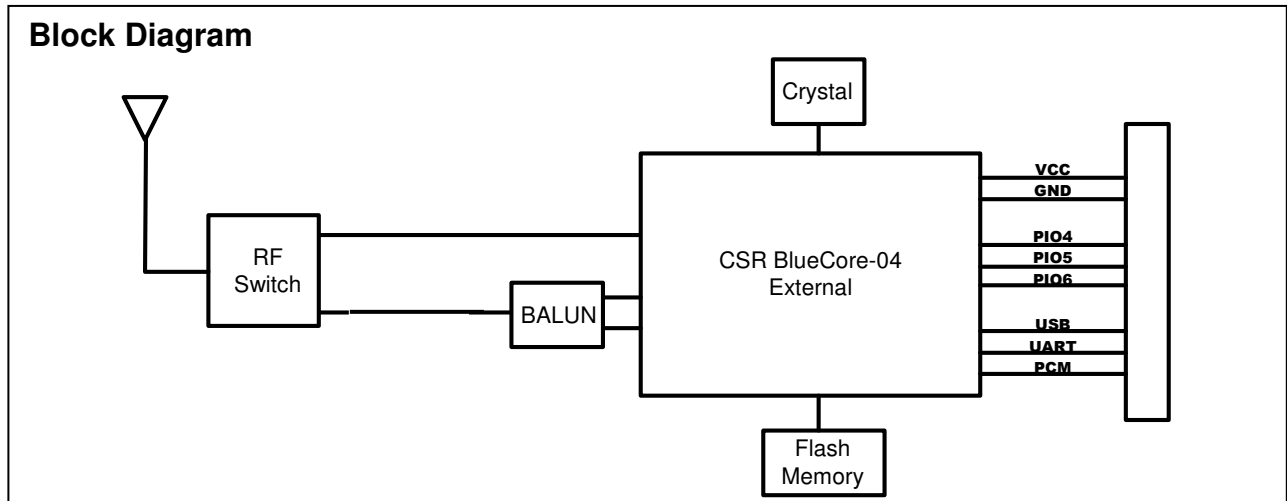

Overview

- Baud rate speeds: 1200bps up to 921Kbps, non-standard baud rates can be programmed.
- Class 2 radio, 60 feet (20meters) distance, 4dBm output transmitter, -80dBm typical receive sensitivity
- Frequency 2402 ~ 2480MHz,
- FHSS/GFSK modulation, 79 channels at 1MHz intervals
- Secure communications, 128 bit encryption
- Error correction for guaranteed packet delivery
- UART local and over-the-air RF configuration
- Auto-discovery/pairing requires no software configuration (instant cable replacement).
- Auto-connect master, IO pin (DTR) and character based trigger modes

Digital I/O Characteristics

2.7V ≤ VDD ≤ 3.0V	Min	Typ.	Max.	Unit
Input logic level LOW	-0.4	-	+0.8	V
Input logic level HIGH	0.7VDD	-	VDD+0.4	V
Output logic level LOW	-	-	0.2	V
Output logic level HIGH	VDD-0.2	-	-	V
All I/O's (except reset) default to weakpull down	+0.2	+1.0	+5.0	uA

Environmental Conditions

Parameter	Value
Temperature Range (Operating)	-40 °C ~ 85 °C
Temperature Range (Storage)	-40 °C ~ 85 °C
Relative Humidity (Operating)	≤90%
Relative Humidity (Storage)	≤90%

Electrical Characteristics

Parameter	Min	Typ.	Max.	Unit
Supply Voltage (DC)	3.0	3.3	3.6	V
Average power consumption				
Radio ON* (Discovery or Inquiry window time)		40		mA
Connected Idle (No Sniff)		25		mA
Connected Idle (Sniff 100 milli secs)		12		mA
Connected with data transfer	40	45	50	mA
Deep Sleep Idle mode		26		uA

* If in SLAVE mode there are bursts of radio ON time which vary with the windows. Depending on how you set the windows that determines your average current.

Radio Characteristics

Parameter	Freq. (GHz)	Min	Typ	Max	Bluetooth Specification	Units
Sensitivity @ 0.1%BER	2.402	-	-80	-86	≤ -70	dBm
	2.441	-	-80	-86		dBm
	2.480	-	-80	-86		dBm
RF Transmit Power	2.402	0	2	4	≤ 4	dBm
	2.441	0	2	4		dBm
	2.480	0	2	4		dBm
Initial Carrier Frequency Tolerance	2.402	-	5	75	75	kHz
	2.441	-	5	75		kHz
	2.480	-	5	75		kHz
20dB bandwidth for modulated carrier		-	900	1000	≤ 1000	kHz
Drift (Five slots packet)		-	15	-	40	kHz
Drift Rate		-	13	-	20	kHz
$\Delta f_{1\text{avg}}$ Max Modulation	2.402	140	165	175	>140	kHz
	2.441	140	165	175		kHz
	2.480	140	165	175		kHz
$\Delta f_{2\text{avg}}$ Min Modulation	2.402	140	190	-	115	kHz
	2.441	140	190	-		kHz
	2.480	140	190	-		kHz

Range Characteristics (Approximate range in office environment)

Range	RN-42
After One Wall	55 feet
After Two Walls	60 feet
After Three Walls	36 feet

The above readings are approximate and may vary depending upon the RF environment. Bluetooth hops in a pseudo-random fashion over the 79 frequencies in the ISM band to adapt to the interference. Data throughput and range vary depending on the RF interference environment.

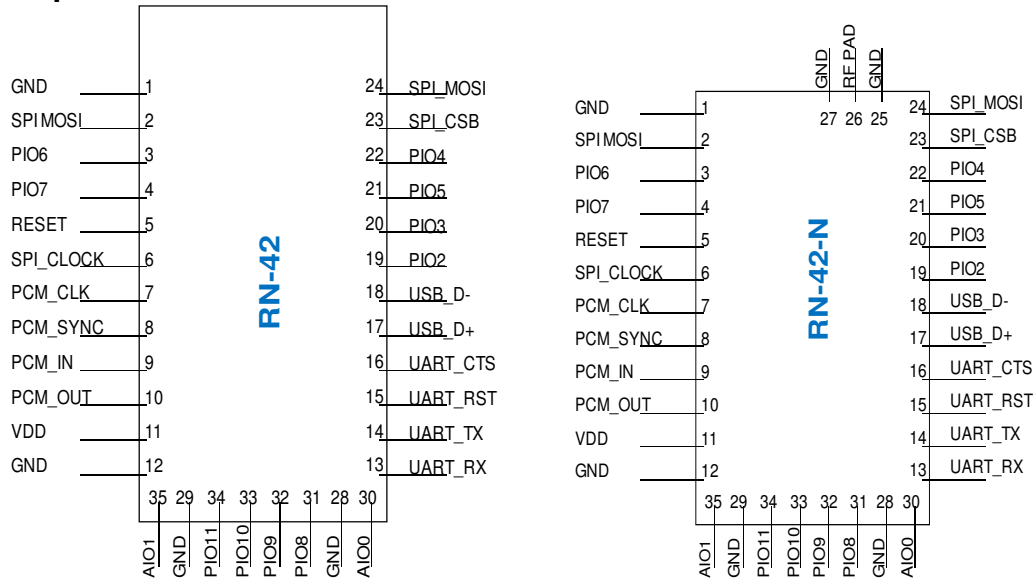
Pin Description

Pin	Name	Description	Default	Voltage
1	GND			0V
2	SPI MOSI	Programming only	No Connect	3V
3	PIO6	Set BT master (HIGH=auto-master mode)	Input to RN42 with weak pulldown	0V-3.3V
4	PIO7	Set Baud rate (HIGH = force 9600, LOW = 115K or firmware setting)	Input to RN42 with weak pulldown	0V-3.3V
5	RESET	Active LOW reset	Input to RN42 with 1K pullup	
6	SPI_CLK	Programming only	No Connect	
7	PCM_CLK	PCM interface	No Connect	
8	PCM_SYNC	PCM interface	No Connect	
9	PCM_IN	PCM interface	No Connect	
10	PCM_OUT	PCM interface	No Connect	
11	VDD	3.3V regulated power input		
12	GND			
13	UART_RX	UART receive Input	Input to RN42	0V-3.3V
14	UART_TX	UART transmit output	High level output from RN42	0V-3.3V
15	UART_RTS	UART RTS, goes HIGH to disable host transmitter	Low level output from RN42	0V-3.3V
16	UART_CTS	UART CTS, if set HIGH, disables transmitter	Low level input to RN42	0V-3.3V
17	USB_D+	USB port	Pull up 1.5K when active	0V-3.3V
18	USB_D-	USB port		0V-3.3V
19	PIO2	Status, HIGH when connected, LOW otherwise	Output from RN42	0V-3.3V
20	PIO3	Auto discovery = HIGH	Input to RN42 with weak pulldown	0V-3.3V
21	PIO5	Status, toggles based on state, LOW on connect	Output from RN42	0V-3.3V
22	PIO4	Set factory defaults	Input to RN42 with weak pulldown	0V-3.3V
23	SPI_CS	Programming only	No Connect	
24	SPI_MISO	Programming only	No Connect	
25	GND	GND for RN42-N		
26	RF Pad	RF Pad for RN42-N		
27	GND	GND for RN42-N		
30	AIO0	Optional analog input	Not Used	
31	PIO8	Status (RF data rx/tx)	Output from RN42	0V-3.3V
32	PIO9	IO	Input to RN42 with weak pulldown	0V-3.3V
33	PIO10	IO (remote DTR signal)	Input to RN42 with weak pulldown	0V-3.3V
34	PIO11	IO (remote RTS signal)	Input to RN42 with weak pulldown	0V-3.3V
35	AIO1	Optional analog input	Not Used	

Typical Application Circuit

Since the RN 41 and RN 42 are functionally compatible, this application diagram applies to RN 41 and RN 42.

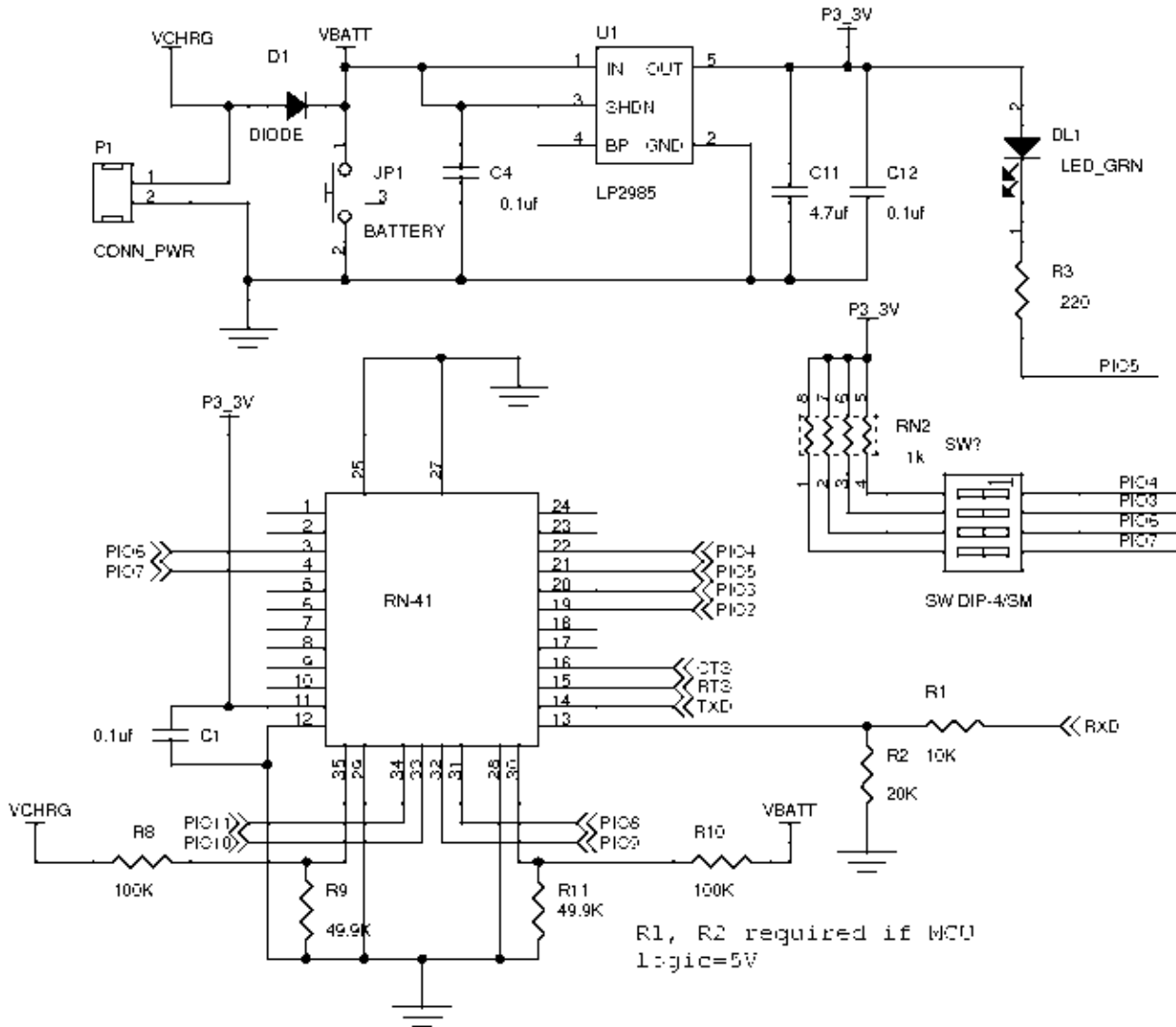

RN-42 Module Dimensions

PCB LAYOUT
 PAD SIZE = 0.8 X 1.30 mm
 (TOP VIEW)

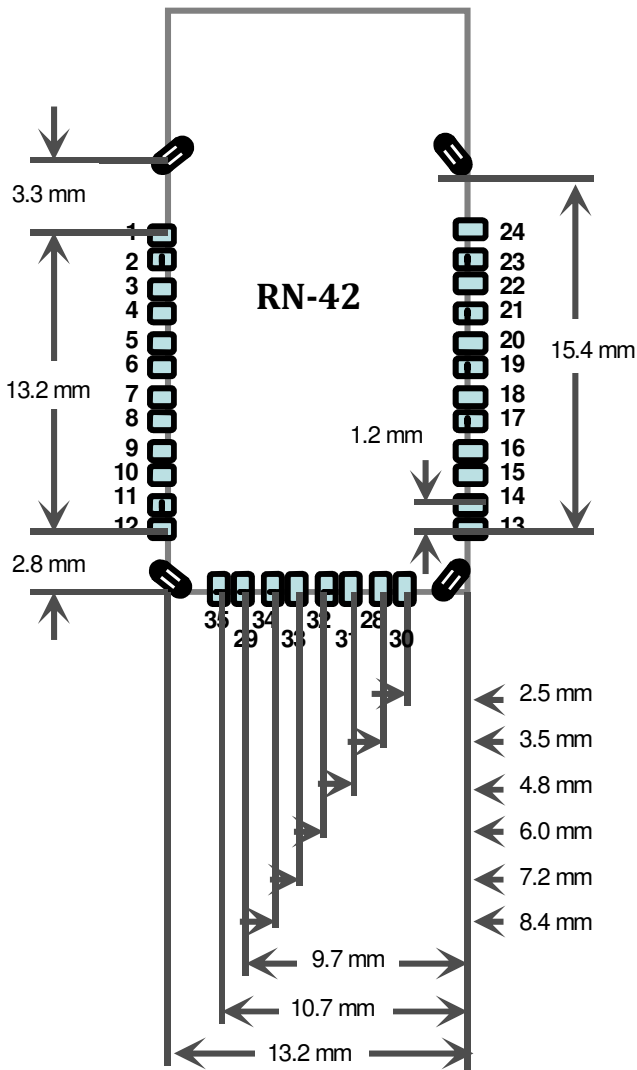

MODULE DIMENSIONS

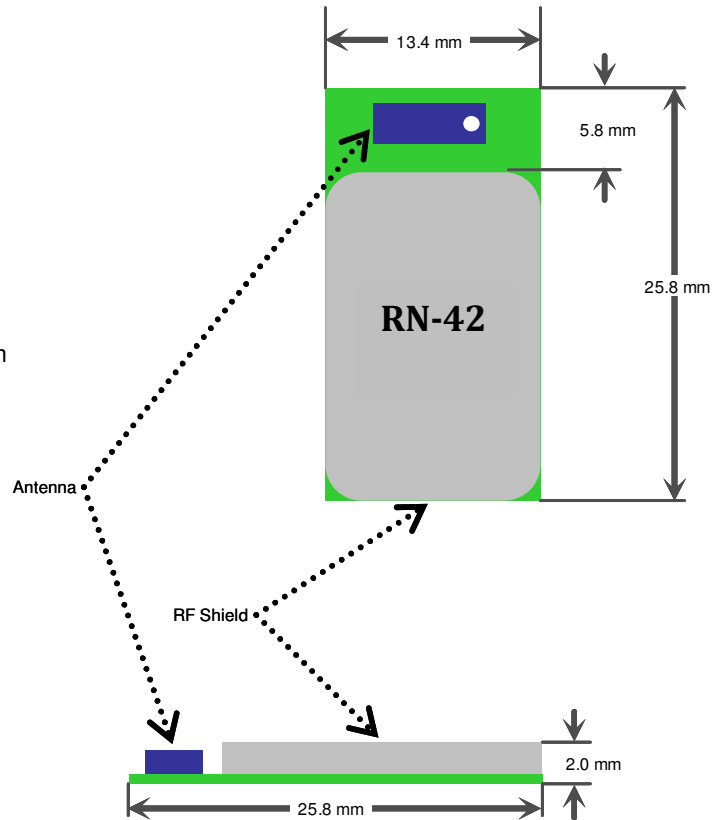

RN-42-N Module Dimensions

PCB LAYOUT
 PAD SIZE = 0.8 X 1.30 mm
 (TOP VIEW)

MODULE DIMENSIONS

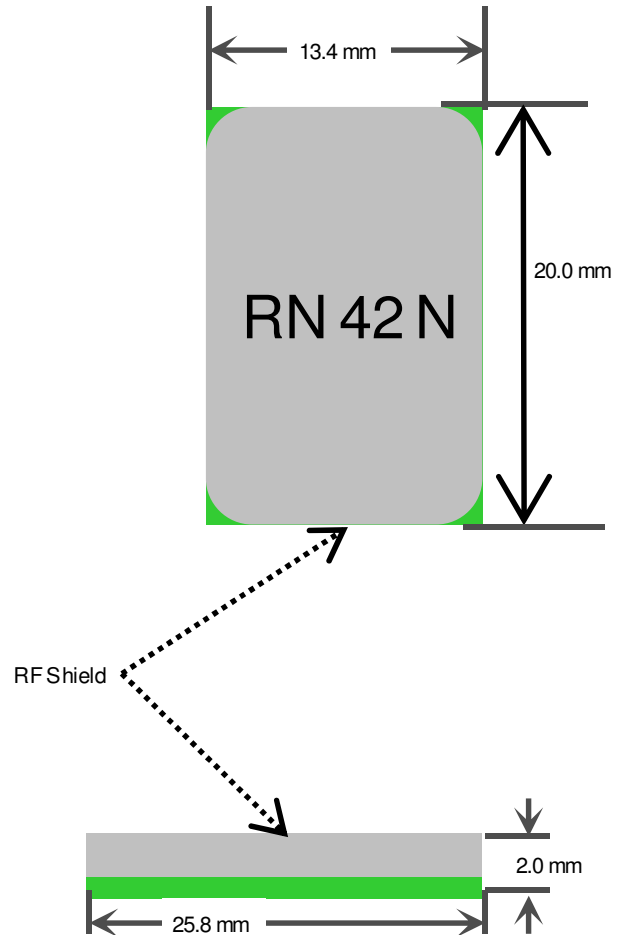
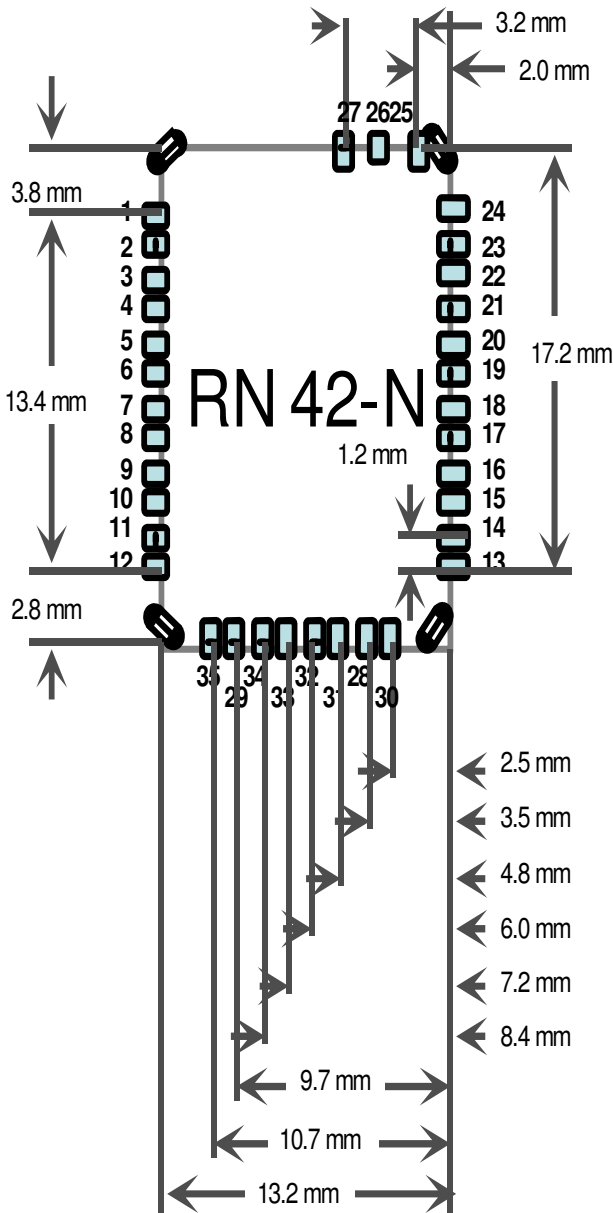

Design Concerns

1. **Reset circuit.** RN-42 contains a weak pullup to VCC, the polarity of reset on the RN42 is ACTIVE LOW. A power on reset circuit with delay is OPTIONAL on the reset pin of the module. It should only be required if the input power supply has a very slow ramp, or tends to bounce or have instability on power up. Often a microcontroller or embedded CPU IO is available to generate reset once power is stable. If not, there are many low cost power supervisor chips available, such as MCP809, MCP102/121, and Torex XC61F.
2. **Factory reset PIO4.** It is a good idea to connect this pin to a switch, or jumper, or resistor, so it can be accessed. This pin can be used to reset the module to FACTORY DEFAULTS and is often critical in situations where the module has been mis-configured. To set Factory defaults start HIGH, then toggle two times.
3. **Connection status.** PIO5 is available to drive an LED, and blinks at various speeds to indicate status. PIO2 is an output which directly reflects the connection state, it goes HIGH when connected, and LOW otherwise.
4. **HCI mode.** The RN42 module must be loaded with special firmware to run in HCI mode. When in HCI mode the standard SPP/DUN applications are disabled.
5. **Using SPI bus for flash upgrade.** While not required, this bus is very useful for configuring advanced parameters of the Bluetooth modules, and is required for upgrading the firmware on modules. The suggested ref-design shows a 6pin header which can be implemented to gain access to this bus. A minimum-mode version could just use the SPI signals (4pins) and pickup ground and VCC from elsewhere on the design.
6. **Minimizing Radio interference.** When laying out the carrier board for the RN42 module the areas under the antenna and shielding connections should not have surface traces, GND planes, or exposed vias. (See diagram to right) For optimal radio performance the antenna end of RN42 module should protrude 5mm past any metal enclosure.

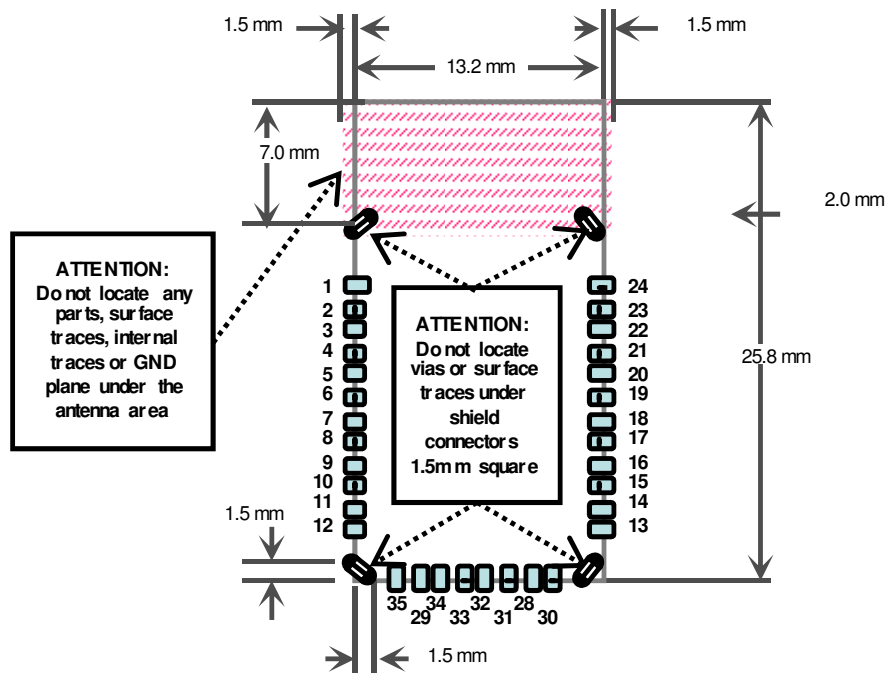

7. Antenna Design. The pattern from the rf_out terminal pad should be designed with 50ohms impedance and traced with straight lines. (see diagram to the right) The rf_out signal line should not run under or near the RN21 module. The GND plane should be on the side of the PCB which the module is mounted. The GND should be reinforced with through-hole connections and other means to stabilize the electric potential.

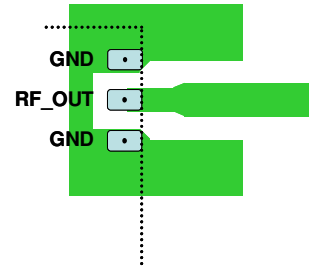

8. Soldering Reflow Profile.

- Lead-Free Solder Reflow
- Temp: 230 degree C, 30-40 seconds, Peak 250 degree C maximum.
- Preheat temp: 165 +- 15 degree C, 90 to 120 seconds.
- Time: Single Pass, One Time

Compliance Information

Category	Country	Standard
Radio	USA	FCC Part 15 Subpart B: 2008 Class B
		FCC CRF Title 47 Part 15 Subpart C
	FCC ID:	T9J-RN42
	EUROPE	ETSI EN 301 489-1 V1.8.1
		ETSI EN 301 489-17 V2.1.1
		ETSI EN 300 328 V1.7.1
	CANADA	IC RSS-210 low power comm. device
	Certification Number: 6514A-RN42	
EMC	USA	FCC CFR47 Part 15 subclass B
	EUROPE	EN 55022 Class B radiated
		EN61000-4-2 ESD immunity
		EN61000-4-3 radiated field
		EN61000-4-6 RF immunity
		EN61000-4-8 power magnetic immunity
Bluetooth	LISTED	B014876
Environmental	RoHS	RoHS compliant

Ordering Information

Part Number	Description
RN-42	Standard Application firmware (SPP/DUN Master and Slave)
RN-42-H	HCI firmware (HCI over H4 UART)
RN-42-U	USB firmware (HCI over USB port, slave device at 12Mbps rate)
RN-42-N	No Antenna, Standard Application firmware (SPP/DUN Master and Slave)
For other configurations, contact Roving Networks directly.	

Visit <http://www.rovingnetworks.com/buynow.php> for current pricing and a list of distributors carrying our products.

Copyright © 2010 Roving Networks. All rights reserved.

The Bluetooth trademark and logo are registered trademarks and are owned by the Bluetooth SIG, Inc. All other trademarks are property of their respective owners.

Roving Networks reserves the right to make corrections, modifications, and other changes to its products, documentation and services at any time. Customers should obtain the latest relevant information before placing orders and should verify that such information is current and complete.

Roving Networks assumes no liability for applications assistance or customer product design. Customers are responsible for their products and applications using Roving Networks components. To minimize the risks associated with customer products and applications, customers should provide adequate design and operating safeguards.

Roving Networks products are not authorized for use in safety-critical applications (such as life support) where a failure of the Roving Networks product would reasonably be expected to cause severe personal injury or death, unless officers of the parties have executed an agreement specifically governing such use.